



Product Information

XV1 • X-Series COM Express™ Module Carrier Board



Document No. 5202 • Edition 26 August 2011

COM Express™ (also known as ETXexpress™) is an open PICMG® standard for Computer-On-Modules, comprised of latest technologies such as PCI Express, Serial ATA, Gigabit Ethernet and SDVO.

With dimensions of 97mm x 144mm, the XV1 is a miniature sized COM Express Module evaluation platform, only slightly larger than the module itself. Nevertheless the XV1 is equipped with a full range of I/O connectors, such as Dual-Gigabit Ethernet, Dual-Screen-Video, quad SATA and quad USB.

A CompactFlash socket is provided for a CF storage card. In addition, the XV1 is equipped with an ExpressCard™ slot, which can be used also for I/O cards. Furthermore, up to two sockets are available for PCI Express® Mini Cards, which are useful especially for wireless applications (e.g. WLAN, WAN, GSM).

Up to four pin headers can be provided for assembly of low profile USB Solid State Drive (SSD) modules, a storage solution for extremely rugged environment conditions. As an alternative, the XV1 can accommodate a 2.5-inch SATA hard disk drive.

The XV1 requires a single +12V supply voltage (3.5mm horizontal plug, other voltages optionally). A matching miniature enclosure is available for the XV1, either ready assembled (boxed PC, IPC) or as accessory. Furthermore, EKF provides design support for custom specific COM Express Module carrier boards and BIOS modification.

With its XV1, EKF offers a versatile small size carrier board for any COM.0 Type 2 compliant COM Express Module, with a variety of options for additional mezzanine I/O and mass storage devices.

Benefits of the XV1 COM Express™ Module Carrier Board

- ▶ Carrier Board for any PICMG COM.0 Compliant COM Express™ Module Type 2
- ▶ Very Small Size 144mm x 97mm
- ▶ Dual-Screen Video Output (DVI-I Integrated Digital & Analog), D-SUB VGA as an Option
- ▶ Dual Gigabit Ethernet Jack, on-Board Gigabit Ethernet NIC
- ▶ Up to 4 x SATA Connectors, 2 x External (eSATA), 1 x Internal (7 Upright), 1 x Internal (7+15 Horizontal) Usage
- ▶ 8 x USB 2.0 Channels, 4 x External, 4 x Internal Usage
- ▶ CompactFlash™ Socket (True IDE Mode Compliant)
- ▶ ExpressCard™ Slot, USB & PCI Express
- ▶ Option Single or Dual PCI Express™ Mini Card Sockets (SMA RP Antenna Connector & SIM Card Holder in Addition, for Wireless Applications)
- ▶ Option Dual or Quad Pin Headers for USB Solid State Drives (SSD)
- ▶ Option on-Board SATA Drive 2.5-Inch
- ▶ Secondary Firmware Hub Option, Phoenix BIOS



XV1 Carrier Board (XB1 on Top)

Simplified Block Diagram

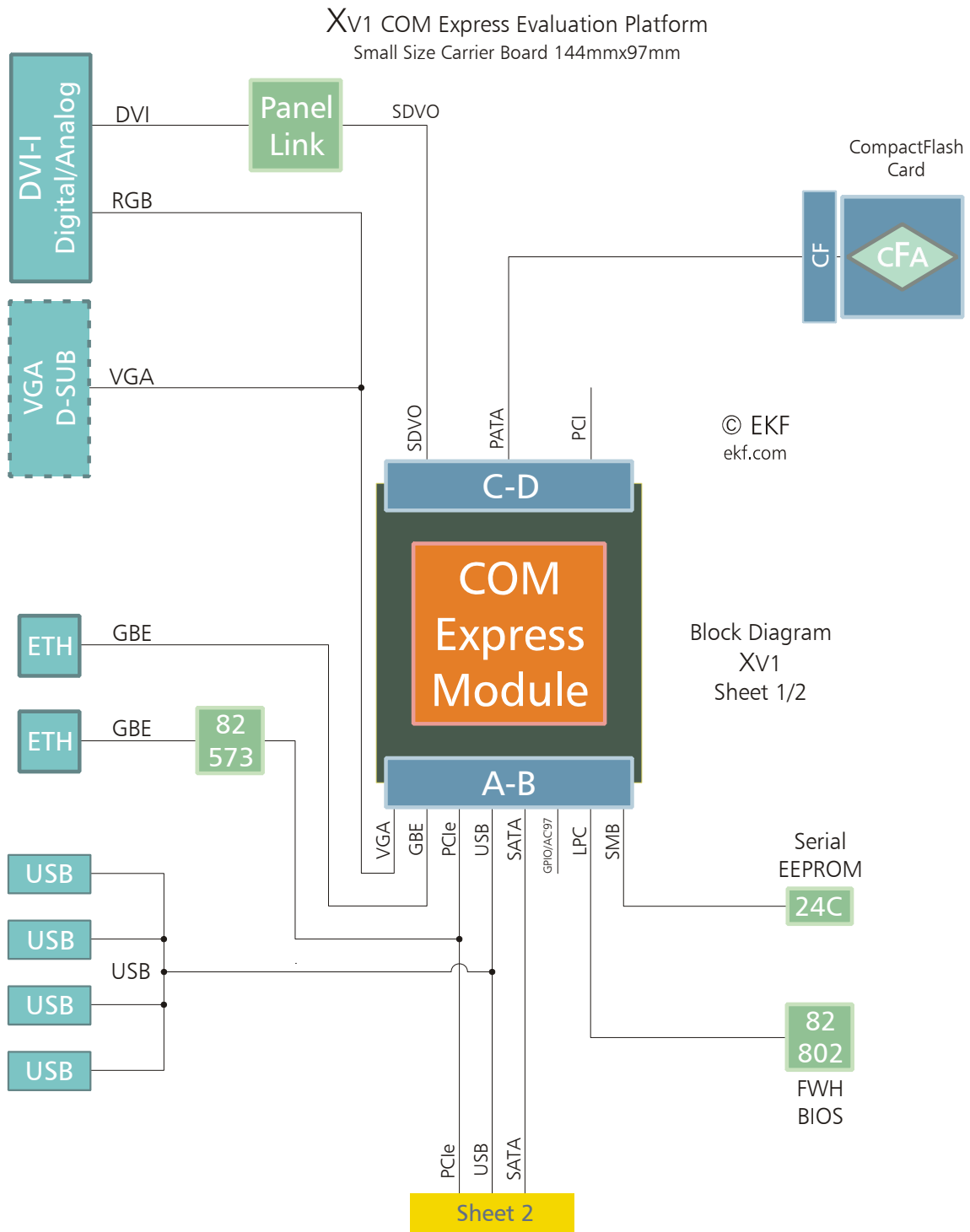

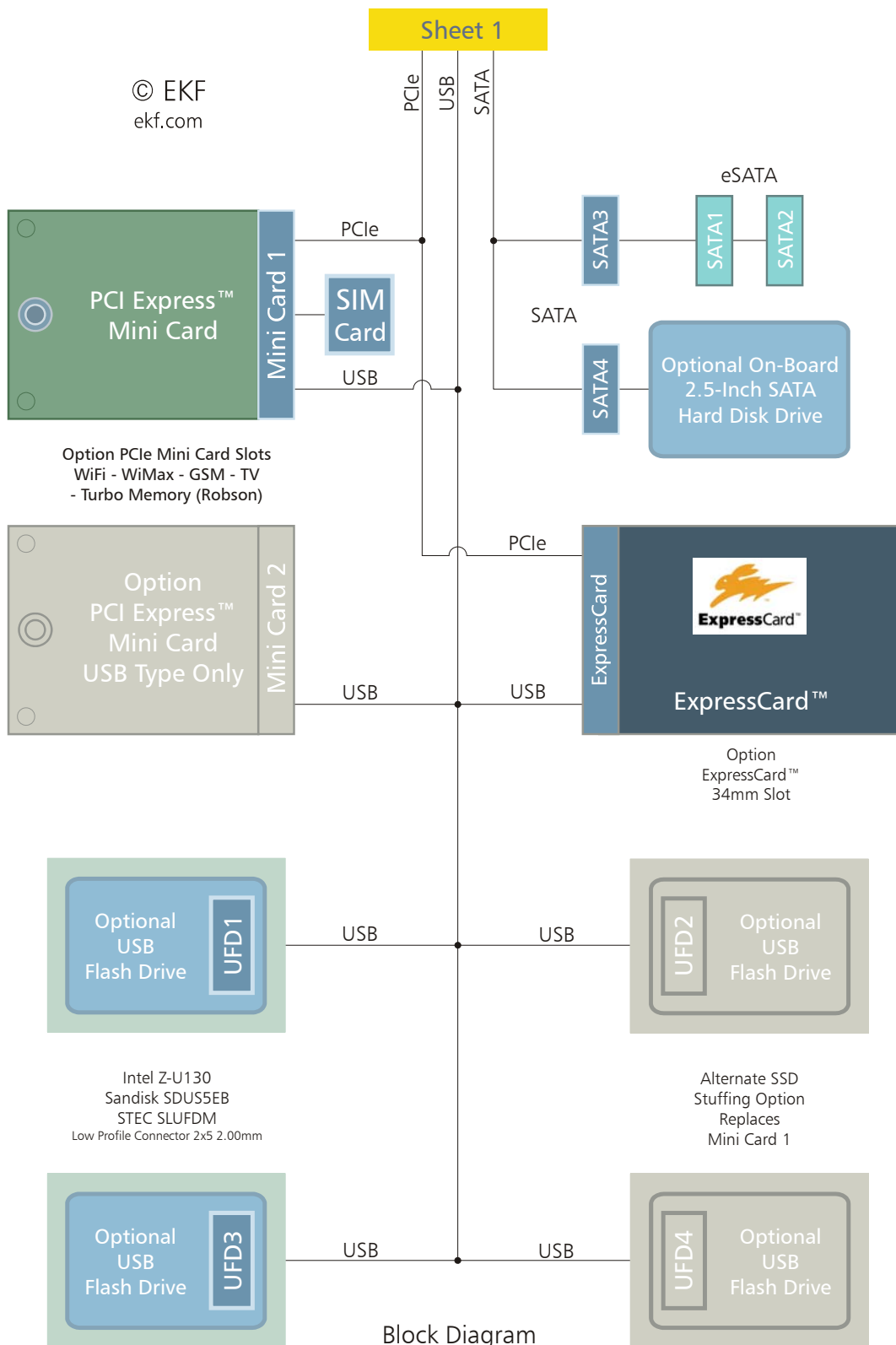



XV1 Top View (COM Express Module Side)



XV1 Bottom View - SATA Drive Option

Assembly Drawing Top/Bottom

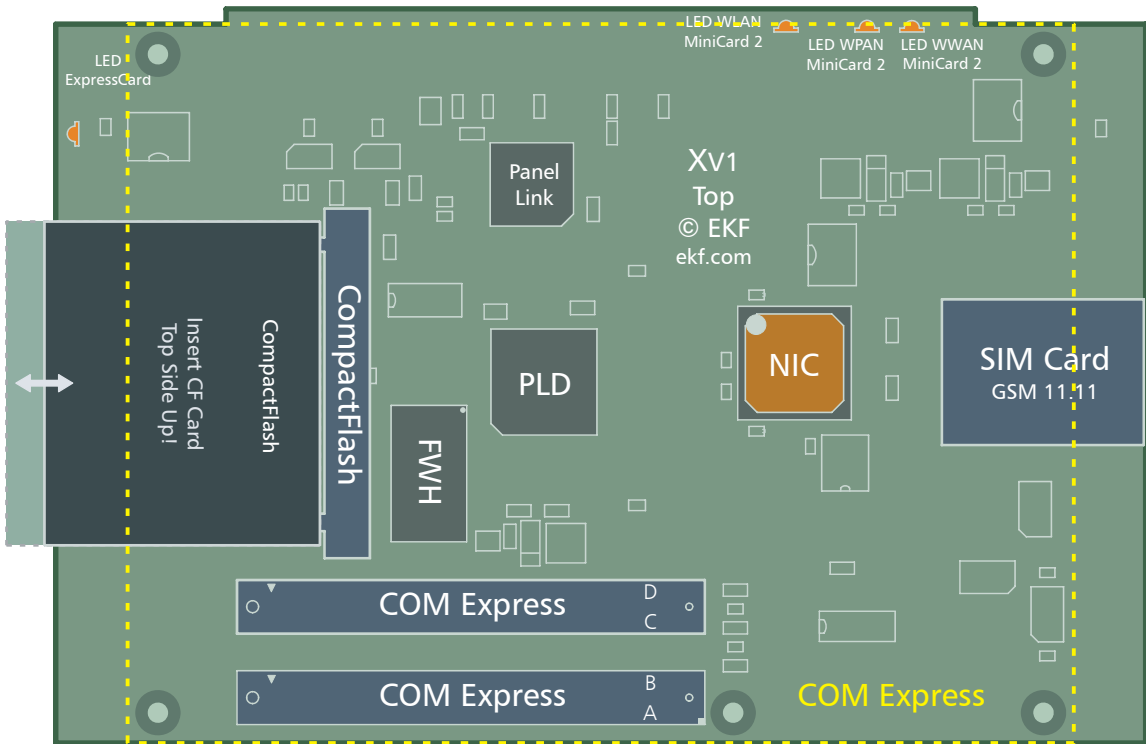

© EKF • XV1 COM Express Carrier Board • ekf.com

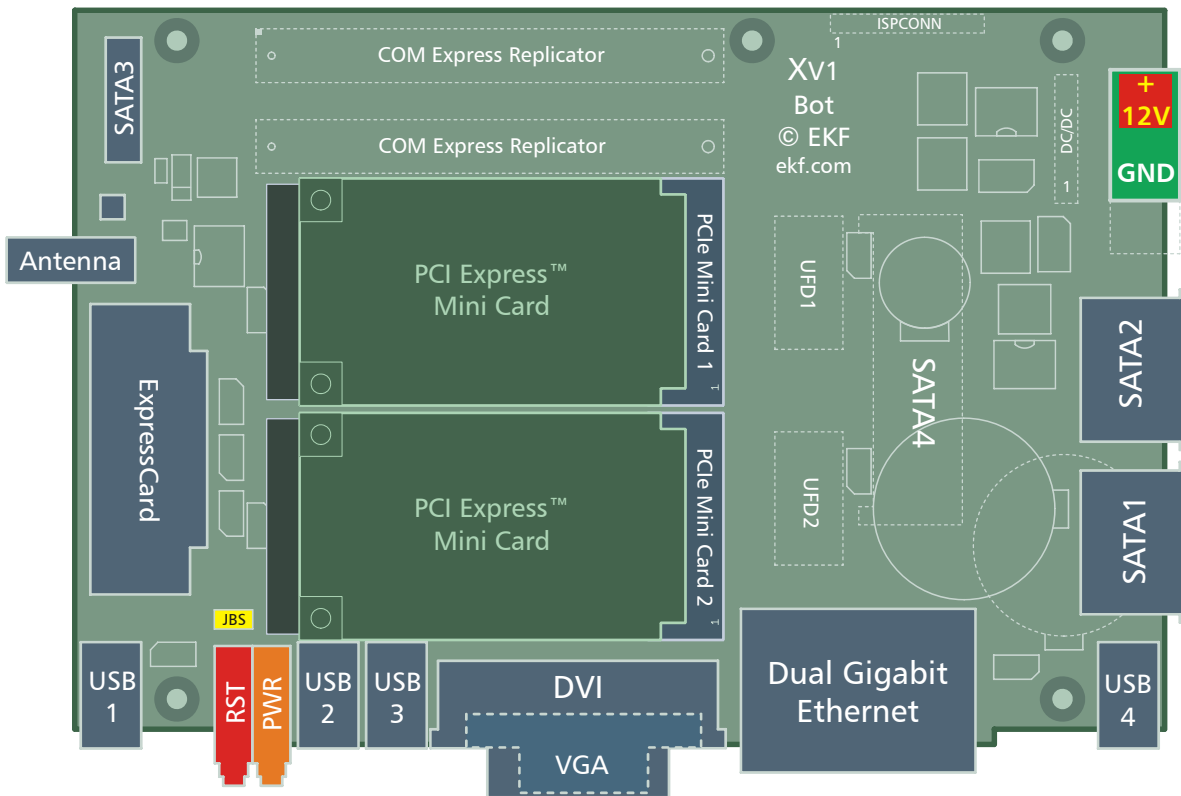

© EKF • XV1 Bottom - Dual PCIe Mini Card Option • ekf.com

Alternate Stuffing Options (Bottom)

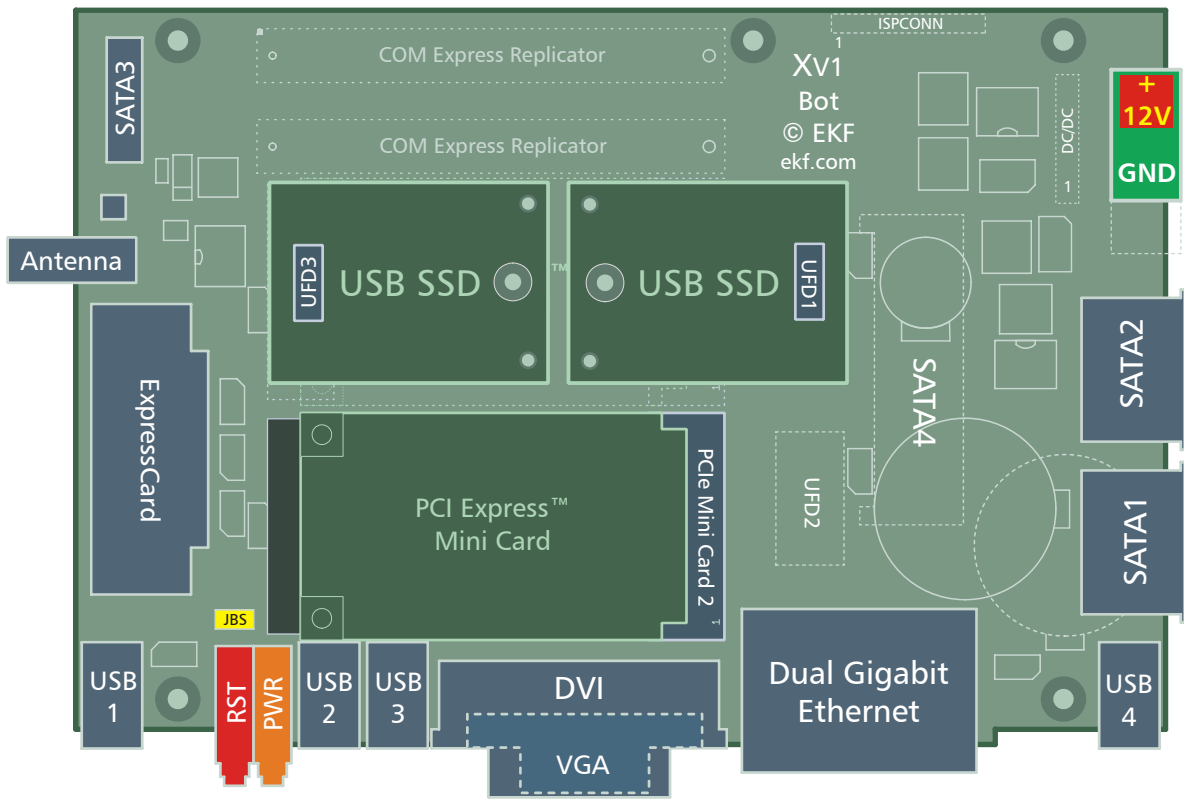

© EKF • XV1 Bottom - Dual USB SSD & Single PCIe Mini Card Option • ekf.com

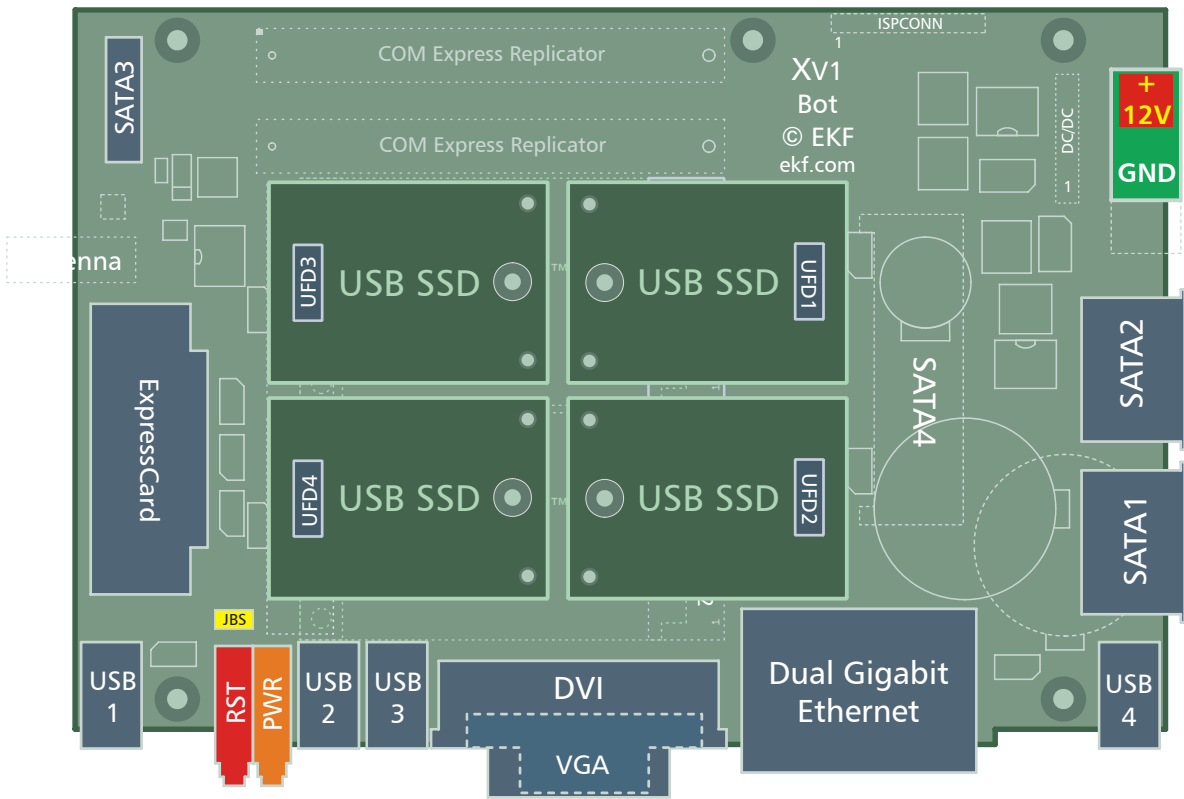

© EKF • XV1 Bottom - Quad USB SSD Option • ekf.com

Hard Disk Option (Bottom)

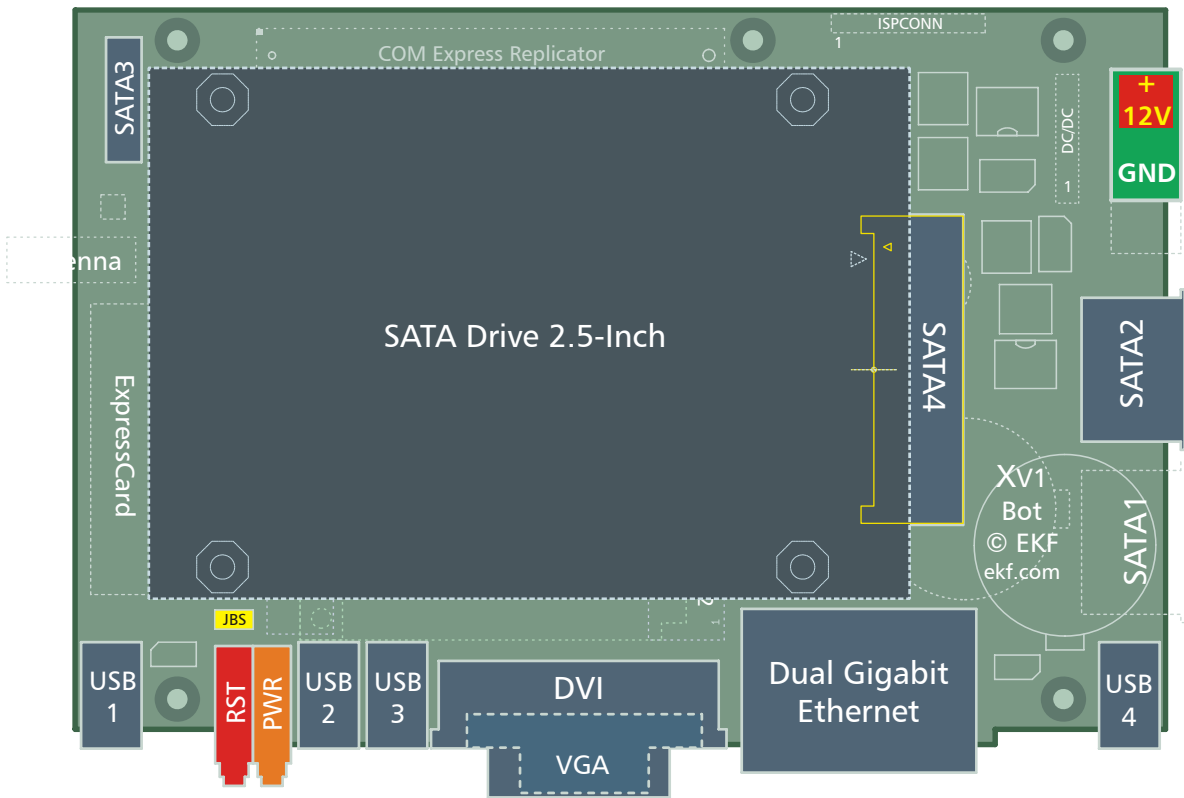

© EKF • XV1 Bottom - SATA HDD Option • ekf.com

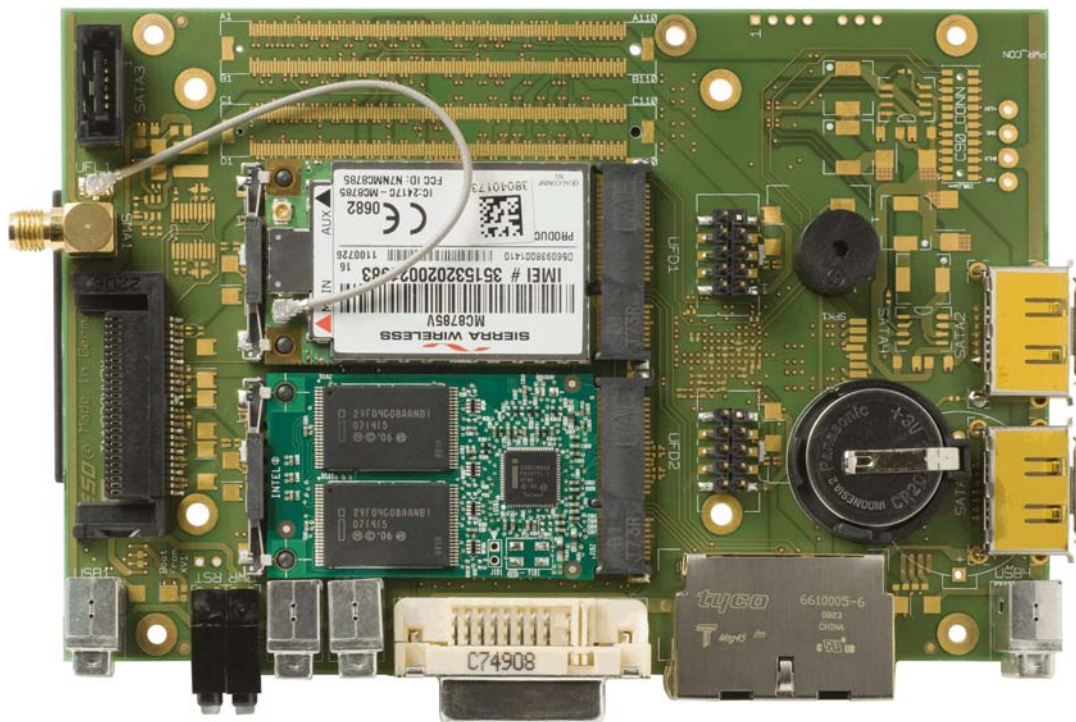

XV1 Bottom View - Dual PCI Express Mini Card Option

Feature Summary XV1

Form Factor	144mm x 97mm Small Size Carrier Board & Evaluation Platform
COM Express™	Suitable for PICMG COM Express R1.0 (COM.0) Basic Module (125x95mm ²), Pin-out Type 2
CompactFlash™	Socket for CF storage card, operated in 'True IDE Mode'
ExpressCard™	Slot for a 34mm style ExpressCard, USB and PCIe support
Option PCI Express® Mini Card	<ul style="list-style-type: none"> ▶ Either one or two sockets for PCI Express® Mini Cards 30.00mm x 50.95mm ▶ For USB and PCI Express based Mini Cards (socket 2 USB only) ▶ SIM Card holder associated with PCIe Mini Card Socket 1 for GSM applications, e.g. UMTS/HSPA & EDGE/GPRS modem ▶ On-Board SMA/RP antenna connector combined with U.FL coax receptacle, to be used for wireless applications with either one Mini Card ▶ Socket 1 suitable for all kind of PCIe Mini Cards, e.g. WLAN/Wi-Fi, WAN, GSM, TV, Turbo Memory (Intel Robson) ▶ Socket 2 (option) suitable for USB type Mini Cards only
Option USB Flash Drive	<ul style="list-style-type: none"> ▶ Up to four pin headers for industrial grade, low profile USB Solid State Drives (SSD), 36.9mm x 26.6mm modules ▶ Variety of industrial grade module vendors e.g. Intel, STEC, Sandisk, SiliconSystems ▶ Rugged solution, fixed by retention screw
Connectivity - Gigabit Ethernet	<ul style="list-style-type: none"> ▶ On-Board PCIe Gigabit Ethernet controller (Intel) ▶ COM Express Module Ethernet port ▶ Dual Gigabit Ethernet jack RJ-45, integrated LEDs
Connectivity - USB	<ul style="list-style-type: none"> ▶ 4 x USB2.0 Type A receptacle for external usage ▶ 4 x USB2.0 ports for internal usage (USB SSD, PCIe Mini Card, ExpressCard)
Connectivity - Video	<ul style="list-style-type: none"> ▶ DVI-I Connector for dual-screen video (splitter cable required) ▶ Digital video output (use straight DVI cable assembly) ▶ Analog video output (use DVI to RGB cable assembly) ▶ Option D-Sub 15 VGA connector - replaces DVI receptacle ▶ On-Board PanelLink transmitter (SDVO to DVI)
Storage - SATA	<ul style="list-style-type: none"> ▶ Up to 4 on-Board SATA connectors ▶ SATA1 & SATA2 for external usage (eSATA shielded receptacles) ▶ SATA3 for latching SATA cable assembly (7-position) ▶ Option SATA4 for direct attachment of a 2.5-inch SATA hard disk drive (22-position data + power)
Option Firmware Hub	<ul style="list-style-type: none"> ▶ On-Board secondary LPC Firmware Hub, for alternate BIOS or custom specific code ▶ Boot selection by jumper settings (JBS), jumper set → enable boot from secondary FWH ▶ Phoenix BIOS custom specific modifications can be offered by EKF
Drivers	Intel networking drivers
Supply Voltage	<ul style="list-style-type: none"> ▶ +12V nominal (maximum allowable voltage tolerances and current consumption mainly as established by the COM Express Module) ▶ Other voltage ranges on request (on board DC/DC module option) ▶ 3.5mm Molex Eurostyle terminal block, for matching horizontal power plug with retention screws (Molex 0395040002, also available from EKF as part no. 245.35.02.20)
Environmental Conditions	<ul style="list-style-type: none"> ▶ Operating temperature: 0°C ... +70°C (CPU dependent) ▶ Storage temperature: -40°C ... +85°C, max. gradient 5°C/min ▶ Humidity 5% ... 95% RH non condensing ▶ Altitude -300m ... +3000m ▶ Shock 15g 0.33ms, 6g 6ms ▶ Vibration 1g 5-2000Hz

Feature Summary XV1

MTBF	tbd
EC Regulations	<ul style="list-style-type: none"> • EN55022, EN55024, EN60950-1 (UL60950-1/IEC60950-1) • 2002/95/EC (RoHS)

subject to changes

Power Connector Assignment

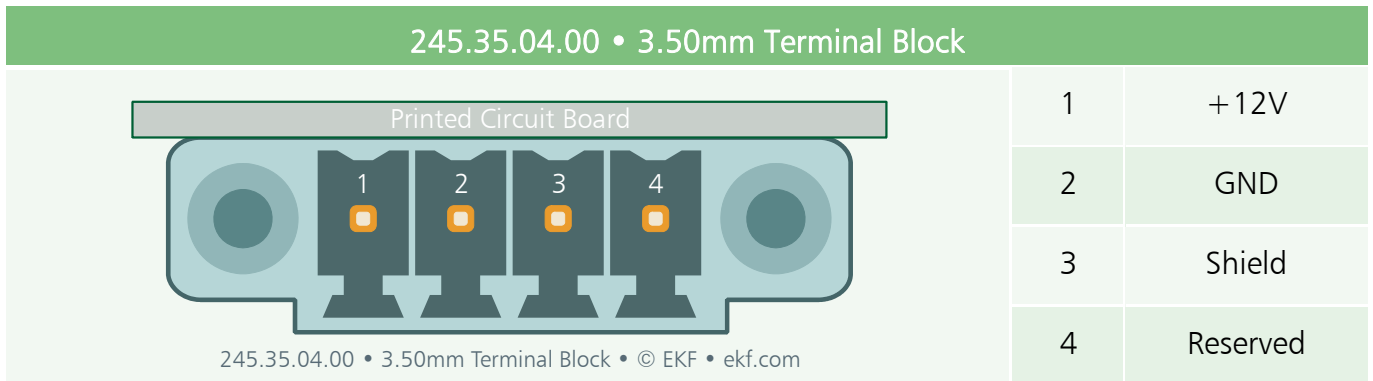

The XV1 is provided with a 3.50mm terminal block for attachment of +12V \pm 10% power on pin 1. The terminal block header is a Phoenix #1843813 or Molex #39506-1004 or equivalent, which mates with a Phoenix #1847071 or Molex #39504-0004 plug. The plug can be fixed by two M2 screws.

While the XV1 itself would accept also a wider than \pm 10% voltage tolerance, the COM Express module actually in use on the XV1 may require a closer tolerance - please refer to the manufacturers data sheet. On request, the XV1 can be provided with a custom specific buck/boost DC/DC converter module for lower and/or higher supply voltages rather than +12V, which requires its power input at pin 4.

Please identify carefully the pin orientation before applying power - the illustration above shows the situation when the XV1 PCB is on top (power connector on bottom of the PCB). This reflects an ordinary assembly stack with the COM Express module on top of the XV1 carrier board.

Warning:

Assembly is not protected against misalignment with respect to +12V and GND
Confusing pin 1 and pin 2 may cause permanent damage to the XV1 and attached peripherals



Industrial Computers Made in Germany
boards. systems. solutions.

EKF Elektronik GmbH
Philipp-Reis-Str. 4
59065 Hamm
Germany



Phone +49 (0)2381/6890-0
Fax +49 (0)2381/6890-90
Internet www.ekf.com
E-Mail sales@ekf.com